

F S W TYPE

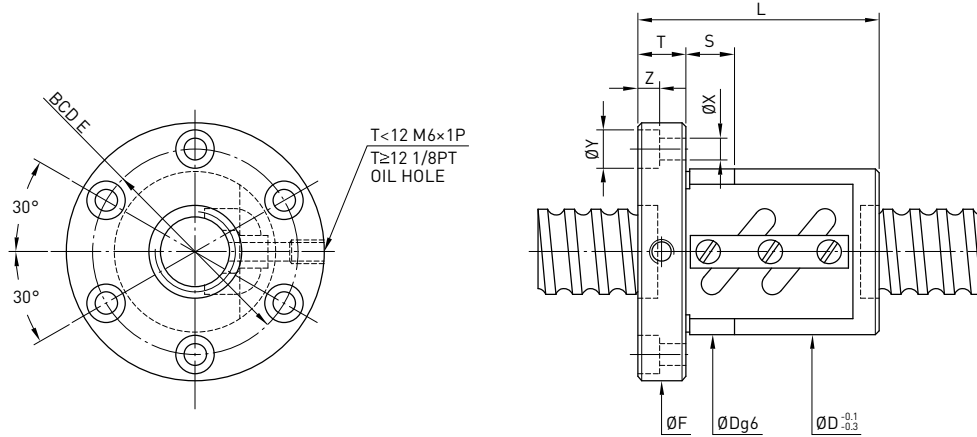

Model	Size		Ball Dia.	PCD	RD	Circuits	Stiffness kgf / μm K	Dynamic Load 1×10^6 revs C (kgf)	Static Load Co (kgf)	Nut		Flange			Bolt			Fit	
	Nominal Dia.	Lead								D	L	F	T	BCD-E	X	Y	Z	S	
12-4B1	12	4	2.381	12.25	9.792	2.5x1	8	383	638	30	38	50	10	40	4.5	8	4	12	
12-4C1				12.25	9.792	3.5x1	9	511	893	30	44	50	10	40	4.5	8	4	12	
12-5B1		5		12.25	9.792	2.5x1	8	383	638	30	40	50	10	40	4.5	8	4	12	
14-5B1	14		14.6	11.324	2.5x1	10	710	1216	34	40	57	11	45	5.5	9.5	5.5	12		
15-10A1	15	10	3.175	15.6	12.324	1.5x1	9	474	781	34	48	57	11	45	5.5	9.5	5.5	12	
15-20A1		20		15.6	12.324	1.5x1	9	474	781	34	62	58	12	45	5.5	9.5	9.5	12	
16-4B1	16	4	2.381	16.25	13.792	2.5x1	14	439	870	34	38	57	11	45	5.5	9.5	5.5	12	
16-5B1				5	16.6	13.324	2.5x1	16	763	1400	40	45	64	12	51	5.5	9.5	5.5	12
16-5B2		16.6			13.324	2.5x2	33	1385	2799	40	60	64	12	51	5.5	9.5	5.5	12	
16-5C1	5	3.175	16.6	13.324	3.5x1	22	1013	1946	40	50	64	12	51	5.5	9.5	5.5	12		
20-5B1				20	20.6	17.324	2.5x1	19	837	1733	44	45	68	12	55	5.5	9.5	5.5	12
20-5B2	20.6	17.324	2.5x2			39	1519	3465	44	60	68	12	55	5.5	9.5	5.5	12		
20-6B1	6	3.969	20.8		16.744	2.5x1	20	1137	2187	48	48	72	12	59	5.5	9.5	5.5	12	
20-6C1				20.8	16.744	3.5x1	28	1512	3041	48	66	72	12	59	5.5	9.5	5.5	12	
25-4B2	25	4	2.381	25.25	22.792	2.5x2	38	976	2776	46	48	69	11	57	5.5	9.5	5.5	12	
25-5B2				5	3.175	25.6	22.324	2.5x2	46	1704	4417	50	60	74	12	62	5.5	9.5	5.5
25-5C1		25.6				22.324	3.5x1	35	1252	3085	50	50	74	12	62	5.5	9.5	5.5	12
25-6B1	6	3.969	25.8	21.744		2.5x1	24	1255	2735	53	44	76	11	64	5.5	9.5	5.5	12	
25-6B2				25.8	21.744	2.5x2	48	2308	5523	56	68	82	12	69	6.6	11	6.5	12	
25-6C1					25.8	21.744	3.5x1	35	1690	3844	56	55	82	12	69	6.6	11	6.5	12
25-10B1	10	4.763	26	21.132	2.5x1	25	1592	3237	60	65	86	16	73	6.6	11	6.5	12		
25-10B2				26	21.132	2.5x2	46	2888	6472	58	97	85	15	71	6.6	11	6.5	12	
25-12B1				12	3.969	25.8	21.744	2.5x1	24	1271	2761	53	60	78	11	64	6.6	11	6.5
28-5B1	28	5	3.175	28.6	25.324	2.5x1	26	984	2466	55	45	85	12	69	6.6	11	6.5	12	
28-5B2				28.6	25.324	2.5x2	50	1785	4932	55	60	85	12	69	6.6	11	6.5	12	
28-6A2		6			28.6	25.324	1.5x2	29	1150	2960	55	55	85	12	69	6.6	11	6.5	12
28-12B2	12	4.763	29	24.132	2.5x2	51	3060	7299	60	110	86	12	73	6.6	11	6.5	12		
28-16B1	16	4.763	29	24.132	2.5x1	25	1686	3649	62	84	89	12	75	6.6	11	6.5	12		
32-5B2	32	5	3.175	32.6	29.324	2.5x2	55	1886	5666	58	60	84	12	71	6.6	11	6.5	12	
32-5C1				32.6	29.324	3.5x1	39	1388	3967	58	50	84	12	71	6.6	11	6.5	12	
32-6B2		32.8			28.744	2.5x2	56	2556	7020	62	68	88	12	75	6.6	11	6.5	12	
32-6C1	6	3.969	32.8	28.744	3.5x1	39	1888	4936	62	55	88	12	75	6.6	11	6.5	12		
32-8B2				8	4.763	33	28.132	2.5x2	59	3284	8453	66	86	100	16	82	9	14	8.5
32-8C1	33	28.132	3.5x1				41	2428	5948	66	70	100	16	82	9	14	8.5	15	
32-10B2		10	6.350				33.4	26.91	2.5x2	60	4810	11199	74	98	108	16	90	9	14
32-10C1	33.4			26.91	3.5x1	44		3519	7785	74	78	108	16	90	9	14	8.5	15	
32-12A2	12	6.350	33.4	26.91	1.5x2	37	3051	6612	74	97	108	18	90	9	14	8.5	15		
32-12B2				33.4	26.91	2.5x2	59	4810	11199	74	110	108	18	90	9	14	8.5	15	

Remark: Stiffness values listed above value are derived from theoretical formula while axial load is 30% of dynamic load rating without preload.

F S W TYPE

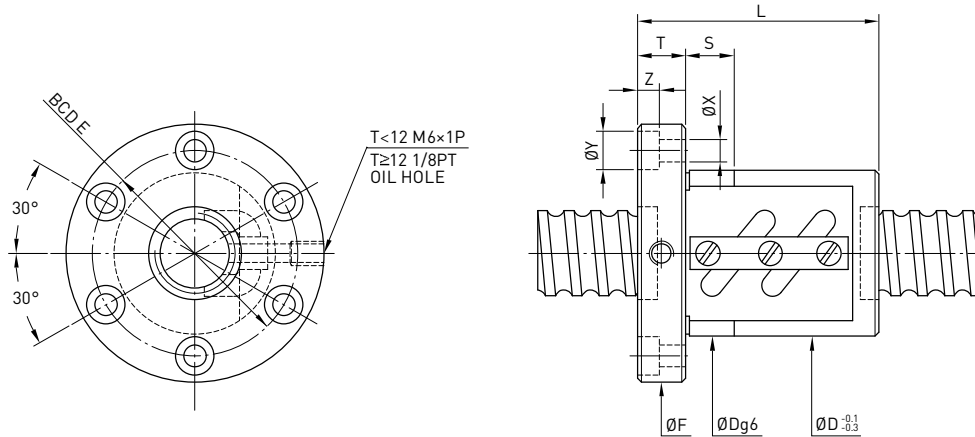

Model	Size		Ball Dia.	PCD	RD	Circuits	Stiffness kgf / μm K	Dynamic Load 1x10 ⁶ revs C (kgf)	Static Load Co (kgf)	Nut		Flange			Bolt			Fit			
	Nominal Dia.	Lead								D	L	F	T	BCD-E	X	Y	Z		S		
32-16A2	32	16	6.350	33.4	26.91	1.5x2	36	3035	6555	74	99	108	16	90	9	14	8.5	15			
32-16B1				33.4	26.91	2.5x1	30	2650	5599	74	94	108	16	90	9	14	8.5	15			
32-16B2				33.4	26.91	2.5x2	59	4810	11199	74	130	108	16	90	9	14	8.5	15			
32-20A2		20		6.350	33.4	26.91	1.5x2	37	3035	6555	74	120	108	16	90	9	14	8.5	15		
32-20B1					33.4	26.91	2.5x1	30	2650	5599	74	98	108	16	90	9	14	8.5	15		
36-6B1					36	6	3.969	36.8	32.744	2.5x1	35	1486	3969	65	50	100	12	82	6.6	11	6.5
36-6B2	36.8	32.744	2.5x2	60				2696	7937	65	68	100	12	82	6.6	11	6.5	12			
36-10B2	10	6.350	37.4	30.91				2.5x2	68	5105	12669	75	102	125	18	98	11	17.5	11	15	
36-12B2	12	6.350	37.4	30.91		2.5x2		65	5105	12668	75	110	125	18	98	11	17.5	11	15		
36-16C1	16	6.350	37.4	30.91		3.5x1		46	3736	8813	80	105	120	18	100	11	17.5	11	15		
40-5B2	40	5	3.175	40.6		37.324		2.5x2	66	2071	7134	68	65	102	16	84	9	14	8.5	15	
40-6B2				6	3.969	40.8	36.744	2.5x2	69	2817	8855	70	72	104	16	86	9	14	8.5	15	
40-8B2				8	4.763	41	36.132	2.5x2	70	3634	10603	74	86	108	16	90	9	14	8.5	15	
40-8C1		8	4.763	4.763	41	36.132	3.5x1	49	2679	7438	74	70	108	16	90	9	14	8.5	15		
40-10B2					10	6.350	41.4	34.91	2.5x2	74	5370	14138	84	102	125	18	104	11	17.5	11	15
40-10C1					10	6.350	41.4	34.91	3.5x1	51	3932	9841	84	82	125	18	104	11	17.5	11	15
40-12B1					12	7.144	41.6	34.299	2.5x1	36	3425	7837	86	81	128	18	106	11	17.5	11	20
40-12B2					12	7.144	41.6	34.299	2.5x2	72	6217	15674	86	117	128	18	106	11	17.5	11	20
40-16A2					16	7.144	7.144	41.6	34.299	1.5x2	42	4007	9405	86	118	128	18	106	11	17.5	11
40-16B1		41.6	34.299	2.5x1				37	3425	7837	86	102	128	18	106	11	17.5	11	20		
45-10B1		45	10	6.350				46.4	39.91	2.5x1	45	3116	7953	88	74	132	18	110	11	17.5	11
45-10B2					46.4	39.91	2.5x2	79	5655	15905	88	104	132	18	110	11	17.5	11	15		
45-12B2	12				7.938	46.8	38.688	2.5x2	81	7627	19799	96	123	142	22	117	13	20	13	20	
50-5A2	50		5		3.175	50.6	47.324	1.5x2	48	1447	5382	80	63	114	16	96	9	14	8.5	15	
50-5A3						50.6	47.324	1.5x3	73	2051	8072	80	73	114	16	96	9	14	8.5	15	
50-6B2						6	3.969	50.8	46.744	2.5x2	81	3093	11149	84	75	118	16	100	9	14	8.5
50-6C2		50.8	46.744	3.5x2				109	4131	15608	84	80	118	15	100	9	14	8.5	15		
50-6B3		50.8	46.744	2.5x3				119	4384	16723	84	93	118	16	100	9	14	8.5	15		
50-8B2		8	4.763	4.763		51	46.132	2.5x2	84	4004	13409	87	88	128	18	107	11	17.5	11	15	
50-8B3					51	46.132	2.5x3	124	5674	20114	87	112	128	18	107	11	17.5	11	15		
50-10B2					10	6.350	51.4	44.91	2.5x2	87	5923	17670	94	104	135	18	114	11	17.5	11	15
50-10B3							51.4	44.91	2.5x3	129	8394	26505	94	134	135	18	114	11	17.5	11	15
50-10C1							51.4	44.91	3.5x1	60	4393	12481	94	84	135	18	114	11	17.5	11	15
50-12B1					12	7.938	7.938	51.8	43.688	2.5x1	46	4420	11047	102	87	150	22	125	13	20	13
50-12B2		51.8	43.688	2.5x2				90	8022	22094	102	123	150	22	125	13	20	13	20		
50-12C1	51.8	43.688	3.5x1	63				5875	15380	102	99	150	22	125	13	20	13	20			
50-30A2	30	6.350	51.4	44.91				1.5x2	52	3834	10658	94	160	135	18	114	11	17.5	11	15	

Remark : Stiffness values listed above value are derived from theoretical formula while axial load is 30% of dynamic load rating without preload.

F S W TYPE

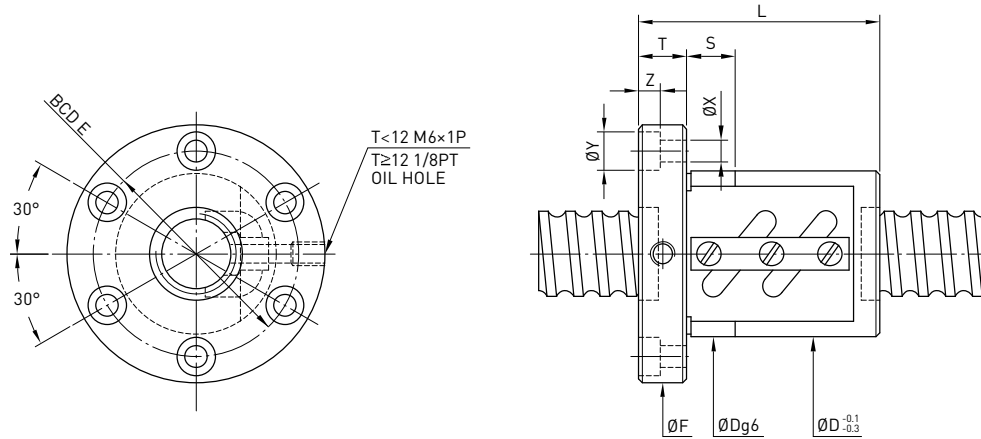

Model	Size		Ball Dia.	PCD	RD	Circuits	Stiffness kgf / μm K	Dynamic Load 1x10 ⁶ revs C (kgf)	Static Load Co (kgf)	Nut		Flange			Bolt			Fit
	Nominal Dia.	Lead								D	L	F	T	BCD-E	X	Y	Z	
55-10B2	55	10	6.350	56.4	49.91	2.5x2	93	6071	19592	102	103	144	18	122	11	17.5	11	20
55-10C1		12	7.938	56.4	49.91	3.5x1	66	4562	13661	100	84	140	18	118	11	17.5	11	20
55-12B2	60	12	7.938	56.8	48.688	2.5x2	95	8392	24390	105	123	154	22	127	13	20	13	20
60-12B2		16	9.525	61.8	53.688	2.5x2	101	8742	26685	112	135	154	18	132	11	17.5	11	20
63-8A2	63	8	4.763	64	59.132	1.5x2	54	2826	10129	104	76	146	18	124	11	17.5	11	20
63-8A3		10	6.350	64	59.132	1.5x3	80	4004	15193	104	92	146	18	124	11	17.5	11	20
63-10B2		12	7.938	64.4	57.91	2.5x2	104	6533	22371	110	107	152	20	130	11	17.5	11	20
63-10B3		16	9.525	64.4	57.91	2.5x3	154	9528	33556	110	137	152	20	130	11	17.5	11	20
63-12B2	70	12	7.938	64.8	56.688	2.5x2	109	8943	28062	118	124	166	22	141	13	20	13	20
63-16B2		16	9.525	65.2	55.466	2.5x2	141	14862	46009	124	153	172	22	147	13	20	13	20
63-20B2		20	9.525	65.2	55.466	2.5x2	141	14862	46009	124	176	172	22	147	13	20	13	20
70-10B2		10	6.350	71.4	64.91	2.5x2	115	6843	25011	124	109	170	20	145	13	20	13	20
70-10B3	70	12	7.938	71.4	64.91	2.5x3	170	9698	37516	124	139	170	20	145	13	20	13	20
70-12B2		16	9.525	71.8	63.688	2.5x2	120	9382	31275	130	125	178	22	152	13	20	13	20
70-12B3	20	9.525	71.8	63.688	2.5x3	170	13296	46912	130	159	178	22	152	13	20	13	20	
80-10B2	80	10	6.350	81.4	74.91	2.5x2	126	7202	28538	130	109	178	22	152	13	20	13	20
80-10B3		12	7.938	81.4	74.91	2.5x3	186	10207	42807	130	139	178	22	152	13	20	13	20
80-12B2		16	9.525	81.8	73.688	2.5x2	130	9797	35422	136	125	185	22	159	13	20	13	20
80-12B3		20	9.525	81.8	73.688	2.5x3	192	13844	53132	136	159	185	22	159	13	20	13	20
80-16B2	100	16	9.525	82.2	72.466	2.5x2	171	16485	58851	145	156	210	28	174	18	26	17.5	25
80-16B3		20	9.525	82.2	72.466	2.5x3	252	23363	88276	145	204	210	28	174	18	26	17.5	25
80-20B2		12	7.938	82.2	72.466	2.5x2	171	16485	58851	145	185	210	28	174	18	26	17.5	25
80-20B3		16	9.525	82.2	72.466	2.5x3	252	23363	88276	145	245	210	28	174	18	26	17.5	25
100-12B2	100	12	7.938	101.8	93.688	2.5x2	156	10761	44596	160	132	224	24	188	18	26	17.5	25
100-12B3		16	9.525	101.8	93.688	2.5x3	229	15251	66894	160	168	224	24	188	18	26	17.5	25
100-16B2		12	7.938	102.2	92.466	2.5x2	200	18123	77425	170	162	248	32	205	22	32	21.5	30
100-16B3		16	9.525	102.2	92.466	2.5x3	305	25684	111637	170	212	248	32	205	22	32	21.5	30
100-20B2		12	7.938	102.2	92.466	2.5x2	200	18123	74425	170	190	248	32	205	22	32	21.5	30
100-20B3		16	9.525	102.2	92.466	2.5x3	305	25684	111637	170	250	248	32	205	22	32	21.5	30

Remark: Stiffness values listed above value are derived from theoretical formula while axial load is 30% of dynamic load rating without preload.